

# SCHAEFER MARINE

## JIB FURLERS

---

Installation Instructions for  
Systems 2000

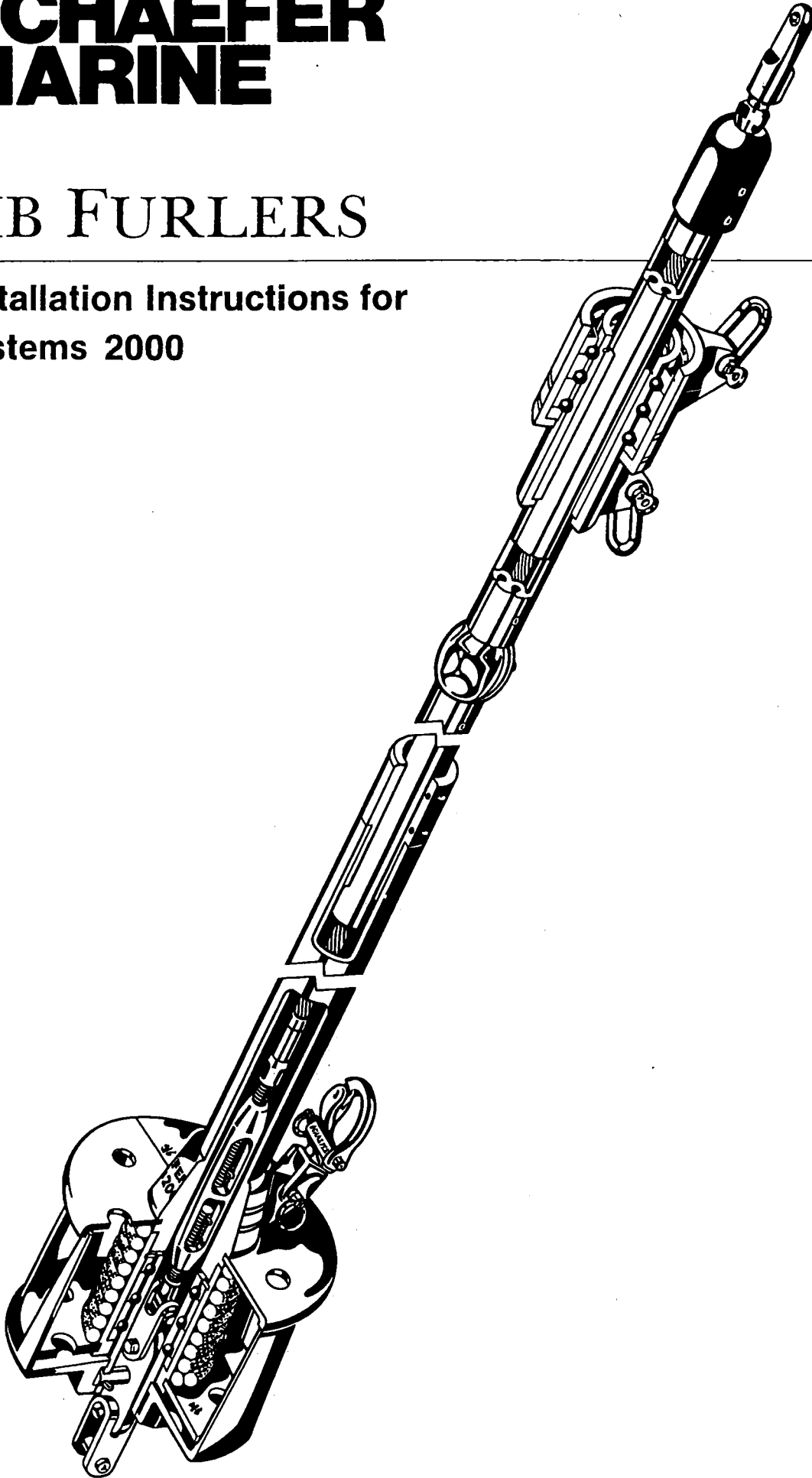

***Thank you...***  
***for purchasing the Schaefer 2000 Furling System.***

When designing this system, our first goal was to build a rugged, durable furler to make sailing safer and more enjoyable. Our second goal was to make the Schaefer furler a logical and simple design, to allow easy installation over your existing headstay.

Where ever possible, parts have been pre-cut and pre-drilled in our factory, to assure a very high level of quality and an easier installation for you.

We suggest that you read the following instructions several times, prior to assembly, to familiarize yourself with the names of the components and each procedure. We also suggest a " trial run " practice assembly prior to the final assembly and riveting of the product.

The installation of the furler may require someone to go aloft in a Bosun's chair to remove the headstay prior to assembly, and to reattach the headstay after assembly. If you are uneasy going aloft in the Bosun's chair or with any other aspect of the assembly procedure, please seek the assistance of a professional yacht rigger.

The services of a professional yacht rigger could end up saving you time and money should you improperly install the furler or encounter an unusual rigging problem.

If any of the assembly steps are unclear to you, please feel free to call us for assistance. Our phone number is:

1-800-528-2266 ( outside Massachusetts )

or

1-508-995-9511 ( in Massachusetts )

Our business hours are 8:30AM to 5:00PM Eastern time.

***Good Sailing!***

# *We care about your safety.*

## 1. Electrical Hazards:

The furling system is manufactured from aluminum extrusions which are highly conductive.

**DO NOT** bring the system close to or in contact with electrical cables or high tension lines. Serious injury or death could result from shocks induced from contact with powerlines.

**DO NOT** assemble and install in unstable weather conditions where lightning is present or eminent. Lightning striking a sailboat mast is likely to travel down the furling system. Contact with the system could be fatal.

## 2. Working Aloft:

**DO NOT** treat the job of going up the mast lightly.

Use a heavy duty Bosun's chair in good condition which provides good support and security. Large, deep tool pockets are helpful.

**NEVER** attach a snap shackle directly to the Bosun's chair. Always bypass the shackle and tie the chair to the halyard.

Use a safety line or a second halyard to back up the halyard being used.

**NEVER** allow anyone to stand under the person working aloft. Any tool or rigging pin dropped from the top of the mast could cause serious injury or death.

## 3. Removing the Headstay:

Make certain that the mast is secured prior to removing the headstay. Deck stepped masts are at particular risk of falling if not fitted with a temporary headstay.

Secure a line to the top of the headstay wire in order to prevent it from dropping on deck when the masthead pin is released.

# *Please be careful !*

## ***Workspace requirements:***

You will require dock space the length of your headstay. In addition, there should be adequate clearance from neighboring boats to allow the finished furler to be hoisted back up to masthead.

We suggest that you place all small parts and tools in buckets to avoid losing them overboard. If your dock or workspace is rough, we suggest that you wrap the components with tape and cardboard to prevent scratches.

## ***Required Tools :***

<b>Quantity</b>	<b>Description</b>	<b>Application</b>
1	Needle nose pliers	to remove cotter pins from rigging pins
1	Wire cutters	to cut the headstay
1	Hacksaw	to cut the sail extrusion to its finished length.
1	Rivet gun with 1/8" nose	to set rivets joining sail extrusions.
1	Flat screwdriver - medium	fasteners in lower drum.
1	Phillips screwdriver - medium	fasteners in lower drum.
2	Crescent wrenches - medium	Sta-Lok® installation.
1	Measuring tape	miscellaneous measurements.
1	Roll of rigging tape	wire cuts and rigging.

\*\*\*\* We also suggest a supply of rags and some acetone to clean excess Loctite® from fasteners and fittings.

# Step 1

Unpack the furler and check the pieces against the following illustration and parts list:

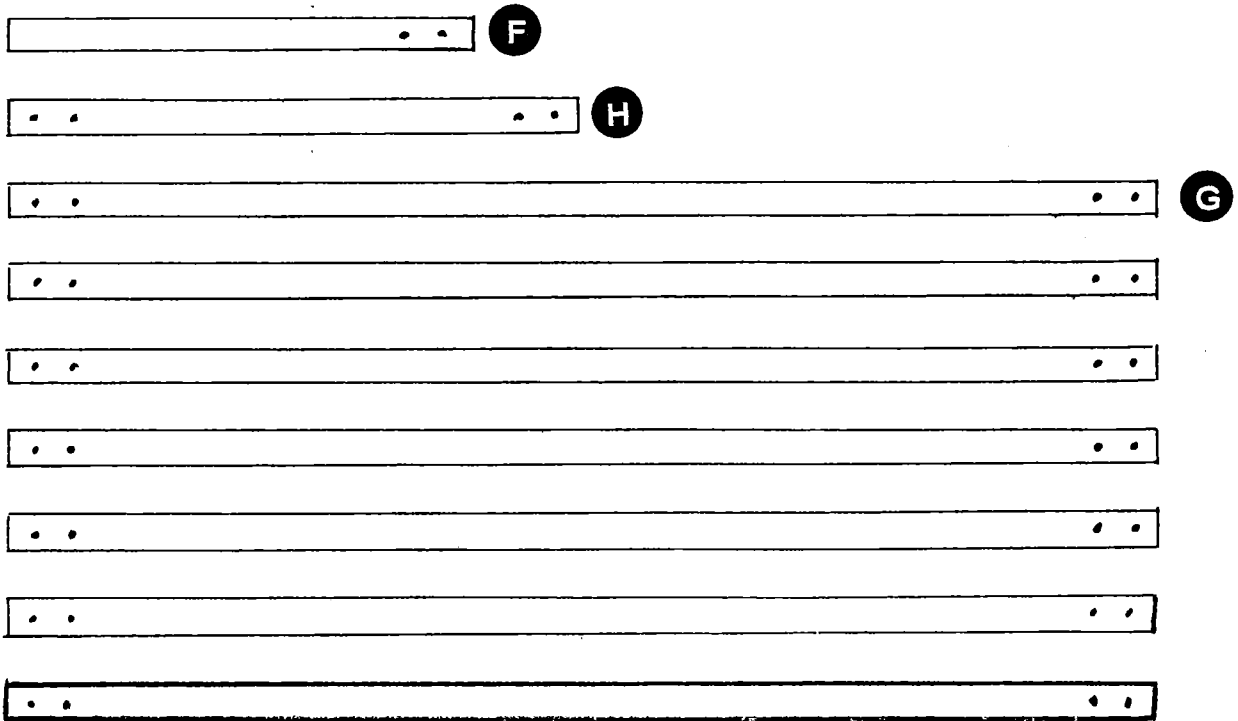
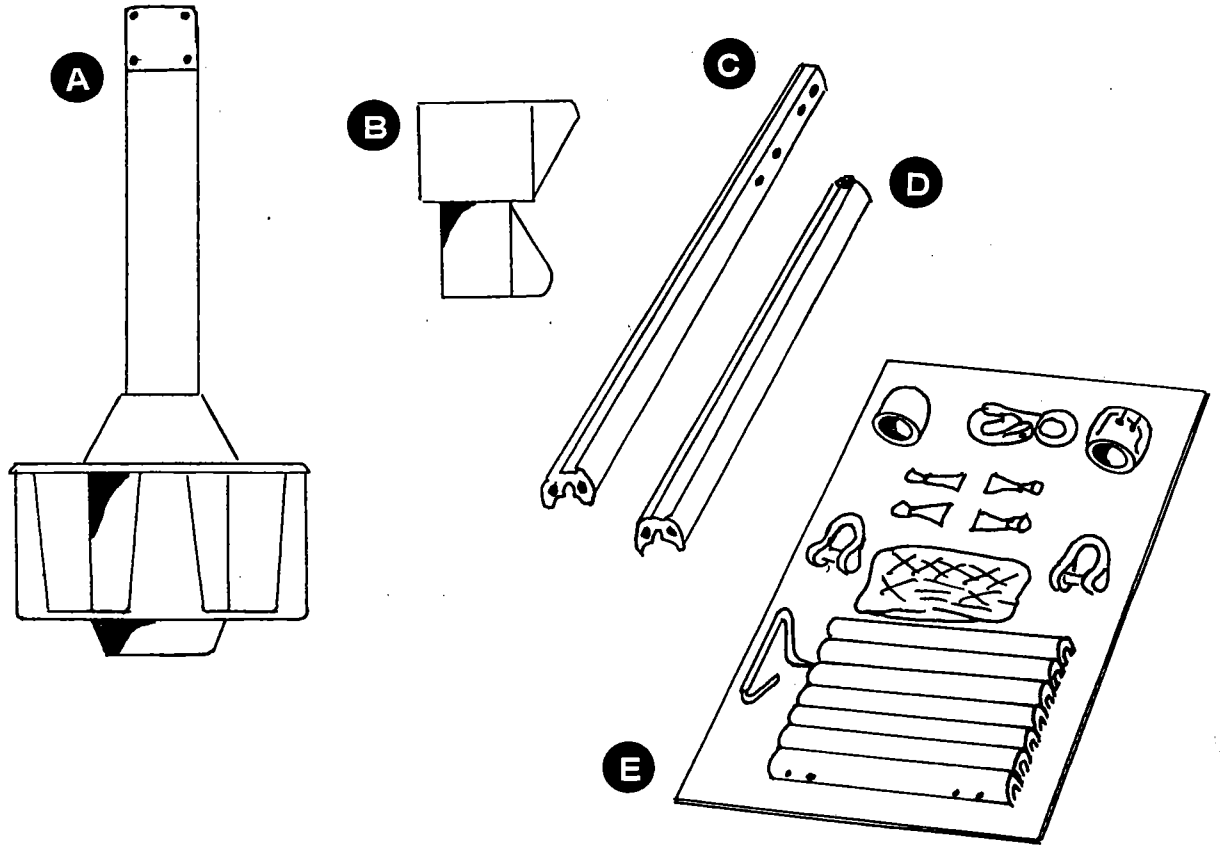

## System 2000 Standard Components

(supplied with all kits)

### Contents of Box:

Quantity	Part No.	Description	Reference
1	33-023-A1	Lower Drum and Torque Tube Assembly	" A "
1	33-022-A	Upper Swivel	" B "
1	14-035-01	Lower Joint / Extrusion Insert	" C "
1	2000-PK *	Shrink Wrapped Small Parts Kit	" E "
1	14-035-03	Upper Extrusion Insert	" D "

\* Small Parts  
Kit

Qty.	Part No.	Description
1	45-25	Tack Snap Shackle
2	93-11	D Shackle
7	14-035-02	Joint / Bearings
1	32-014	Top Cap
1	45-223	Sail Feeder - (for #6 luff tape)
1	24-039	Plastic Bag with Spare Parts
1	24-040	Allenhead Wrench Kit
1	22-321	3/16" Long Handle Allen Wrench
1	30-067-PK	Plastic Bag with Rivets for Joints
3	95-053	Loctite® - Blue
1	SK-4622-01	Loctite® - Red

### Contents of Round Tube:

1	14-034-M01	Bottom Extrusion ( 21" long )	" F "
7	14-034-M02	Sail Extrusion ( 72" long )	" G "
1	14 034-M03	Half Length Sail Extrusion	" H "

### Additional Parts Included With Different System 2000 Order Numbers: (shipped in box)

Order #	Quantity	Part #	Description:
2000-00	1	46-016	1/2" Pin Lower Toggle Only (Or fittings as Specified on the Shipping Order)
2000-01	1	46-016	1/2" Pin Lower Toggle
	1	11-600-26	Sta-Lok® fitting for 1/4" wire with 1/2" pin.
2000-02	1	46-016	1/2" Pin Lower Toggle
	1	11-600-27	Sta-Lok® Fitting for 9/32" wire with 1/2" pin
2000-03	1	46-018	1/2" Pin Lower Toggle
	2	11-600-25	Sta-Lok® Fitting for 5/16" wire with 5/8" pin
	1	46-019	Adjustable Link Tangs - 5/8" pins.

---

## Special Instructions for 2000-03 Kits:

---

( 5/16" wire with 5/8" turnbuckle and 5/8" pins )

The system 2000 drum unit provides a 1<sup>3</sup>/<sub>4</sub>" inside diameter clearance hole for turnbuckle bodies and toggles. Some 5/8" turnbuckles incorporate toggles which exceed this dimension and will not fit inside the bottom drum.

If this is the case with the headstay on your boat, the 2000-03 kit has been supplied with a set of adjustable link tangs. These tangs were designed to replace your existing turnbuckle, providing the same range of adjustment and strength, but within the space limitations of the bottom drum unit.

We suggest that you make this conversion first, so that the remainder of the installation procedure will follow the steps shown in this manual.

**If your existing turnbuckle and lower toggle will fit through a 1<sup>3</sup>/<sub>4</sub>" diameter hole, please ignore these instructions and proceed to step # 2.**

If you do not utilize the link tangs and wish to return them for credit, please contact our customer service department at Schaefer Marine.

- A. Remove the headstay and lay out on the dock.
- B. Close the turnbuckle (tighten).
- C. Close the link tang system to it's minimum length.
- D. Add the heavy duty bottom toggle to the link tangs.

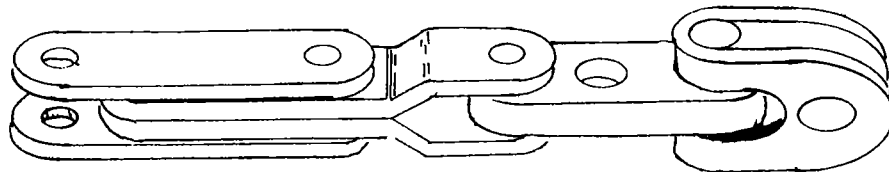
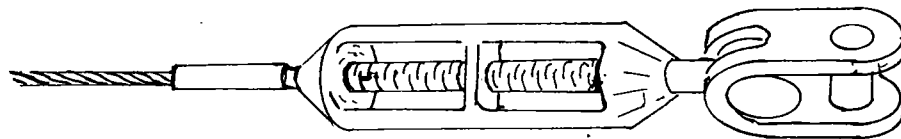

- E. Align the bottom pins of the old turnbuckle and bottom toggle.
- F. Make a mark on the wire 1" above the center of the upper hole of the link tang.
- G. Cut the wire at the mark.

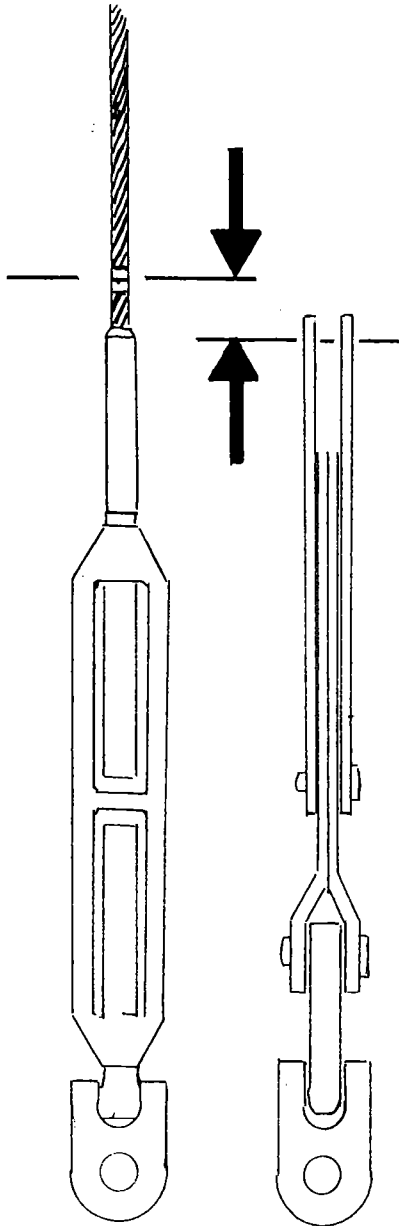

- H. Reverse the wire (turn end for end) and connect the old top end fitting to the top hole in the link tangs. The Sta-Lok<sup>®</sup> fitting supplied with this kit will be installed on the cut (upper) end of the wire after the furler is assembled.
- I. Read the cautionary notes in steps #2 and #3, then proceed to step #6.

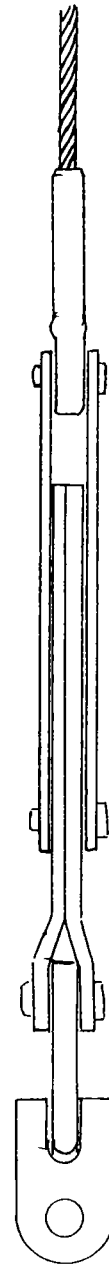



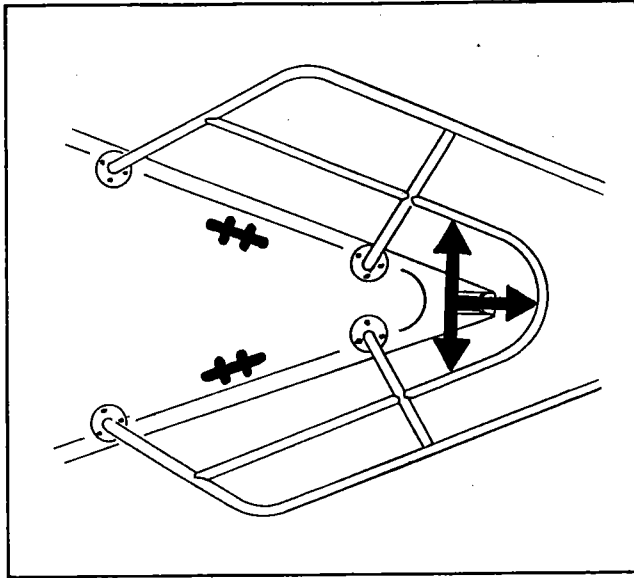

## Step 2

Check to make sure there is adequate clearance for the drum from the bow pulpit, anchor roller and other hardware mounted on the bow. It may be necessary to install an extension tang at the bottom of the system in order to raise the drum above these fittings. 6" long tangs are available from Schaefer if this is a problem. Confirm that the wire and rigging pin sizes are the same as the parts supplied in the kit.

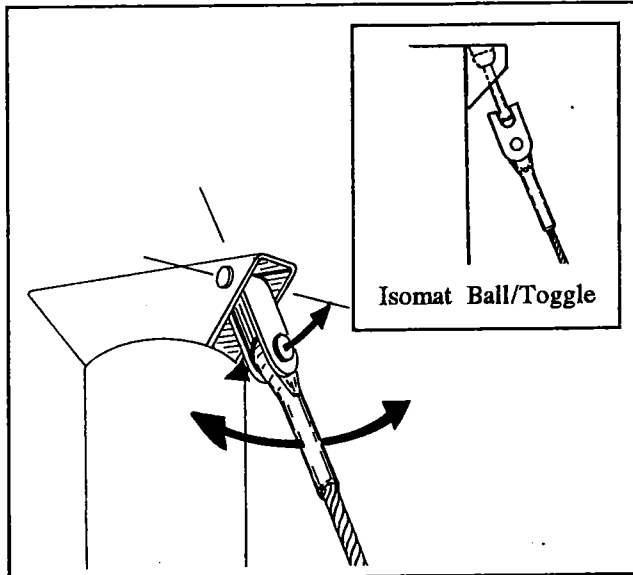

## Step 3

Inspect the connection of the headstay at the masthead. **There must be a toggle at the masthead to allow a "universal" motion of the headstay!** Spars manufactured by Isomat that do not have a separate masthead ball/toggle fitting **MUST** have the headstay modified to include this fitting. **Failure to provide the headstay with a proper toggle could result in eventual failure of the wire end fittings and loss of the mast!**

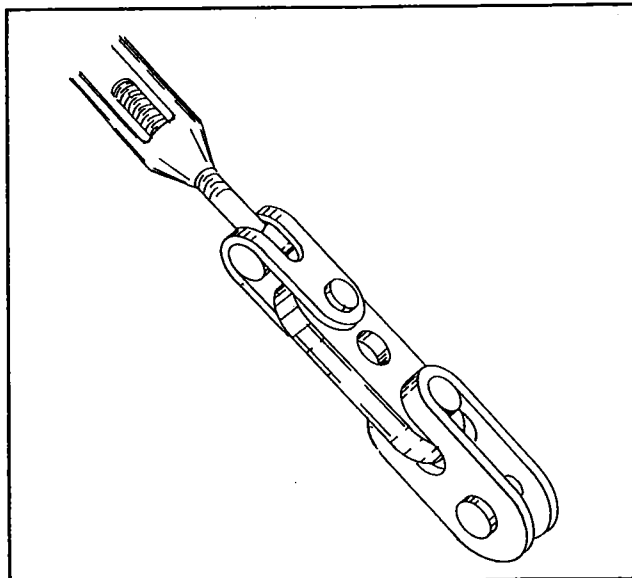

## Step 4

Make sure the mast is temporarily supported and then remove the headstay.

Lay the headstay out on the dock or work area. Add the **HEAVY DUTY BOTTOM TOGGLE** to the bottom end of the headstay turnbuckle. Close the turnbuckle (tighten) at this time.

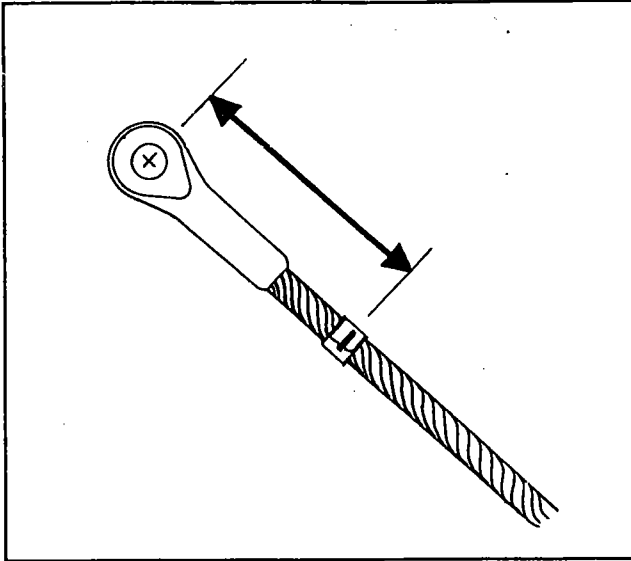

## Step 5

Measure down 5" from the center of the hole in the old wire fitting or swage stud at the top of the wire. Wrap tape around the wire and make a mark with a pencil or pen. Cut the wire at this mark.

**Note:** The top of the wire is being shortened to compensate for the length added by the HEAVY DUTY TOGGLE added in step #4, and the eye portion of the Sta-Lok® added in step #27. If additional link tangs or masthead toggles are being added, additional wire should be removed.

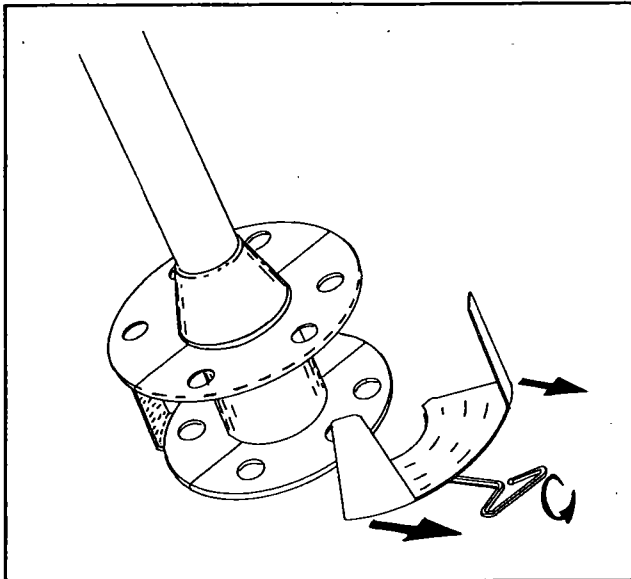

## Step 6

Remove the STAINLESS STEEL CAGES from the LOWER DRUM AND TORQUE TUBE ASSEMBLY.

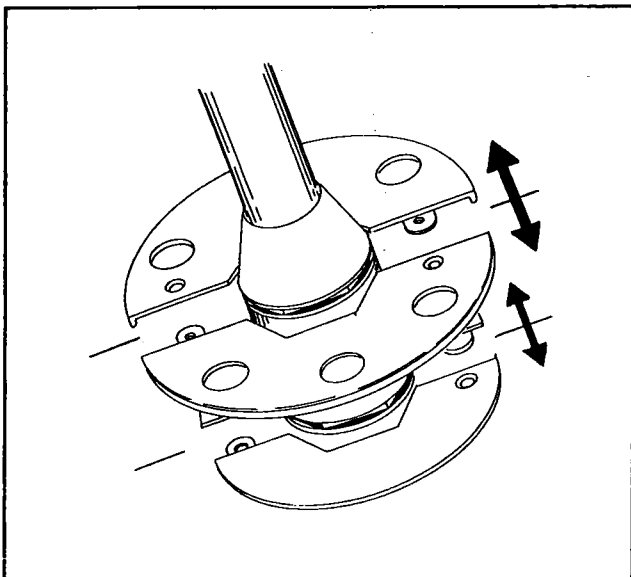

## Step 7

Remove the SPLIT TOP PLATES and SPLIT BOTTOM PLATES from the LOWER DRUM AND TORQUE TUBE ASSEMBLY.

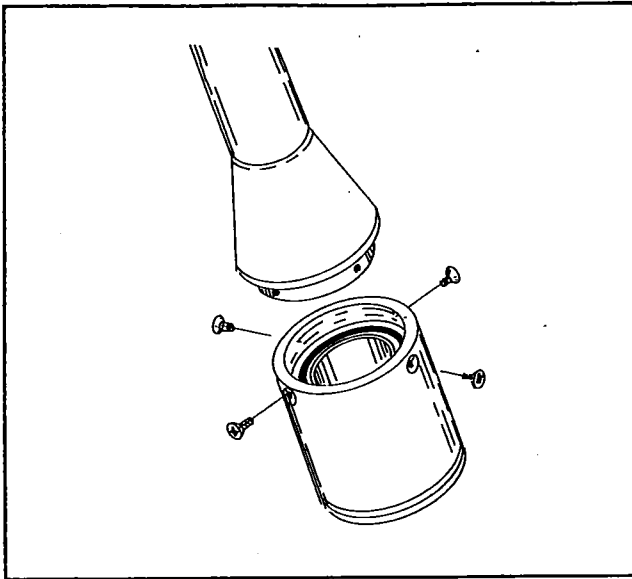

### **Step 8**

Remove the flat head fasteners in the side of the LOWER DRUM, releasing the TORQUE TUBE.

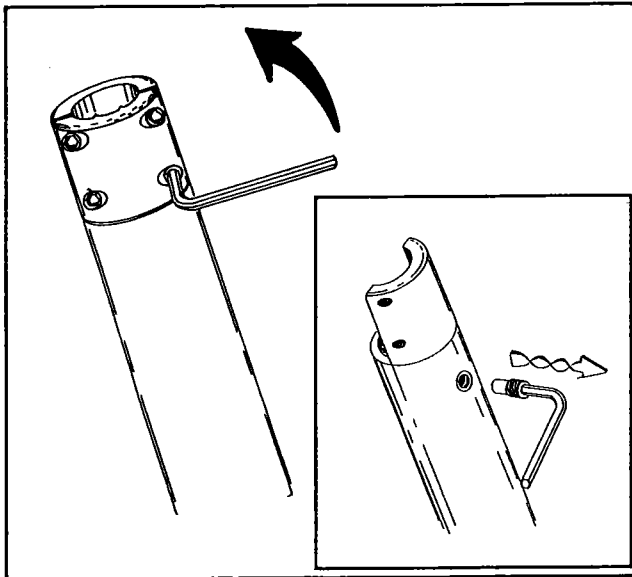

### **Step 9**

Remove the four allenhead fasteners in the top of the TORQUE TUBE. Remove the CLAMP.

### **Step 10**

Remove the STOP PIN from the side of the TORQUE TUBE.

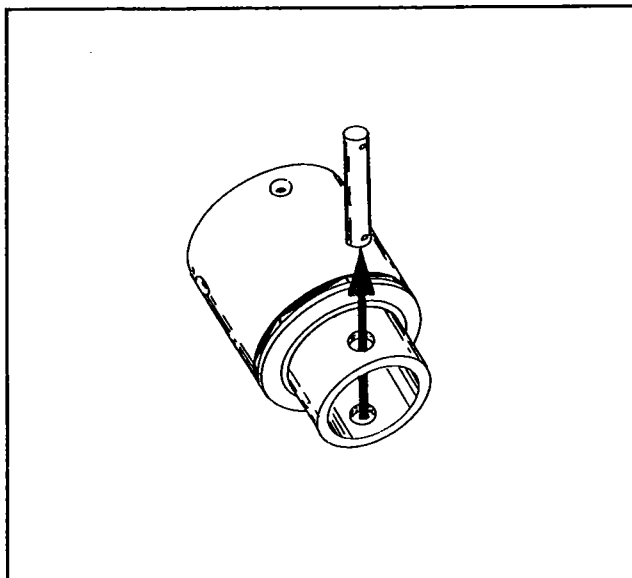

### **Step 11**

Remove the stainless steel BASE PIN from the LOWER DRUM UNIT.

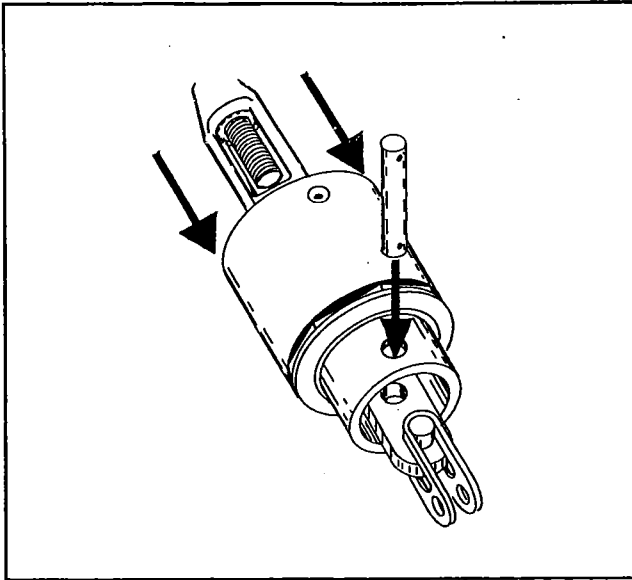

## Step 12

Slide the LOWER DRUM UNIT over the top (cut end) of the wire and down to the HEAVY DUTY TOGGLE.

Replace the BASE PIN thru the LOWER DRUM UNIT and the hole provided in the middle of the HEAVY DUTY TOGGLE.

Replace COTTER PINS in BASE PIN. Split the COTTER PINS to prevent them from falling out, but do not bend them over as this might make it difficult to replace the STAINLESS STEEL CAGE.

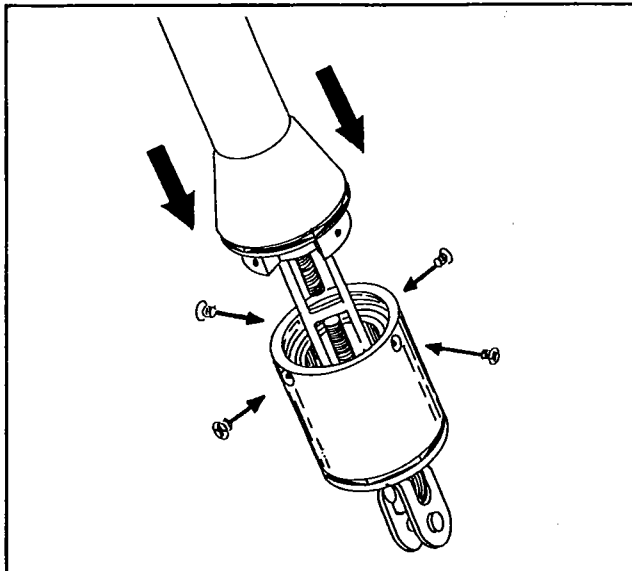

## Step 13

Slide the TORQUE TUBE over the top end of the wire, slide down and fasten temporarily to the LOWER DRUM UNIT.

Replace the STOP PIN in the TORQUE TUBE to the point of being flush with the outside of the tube.

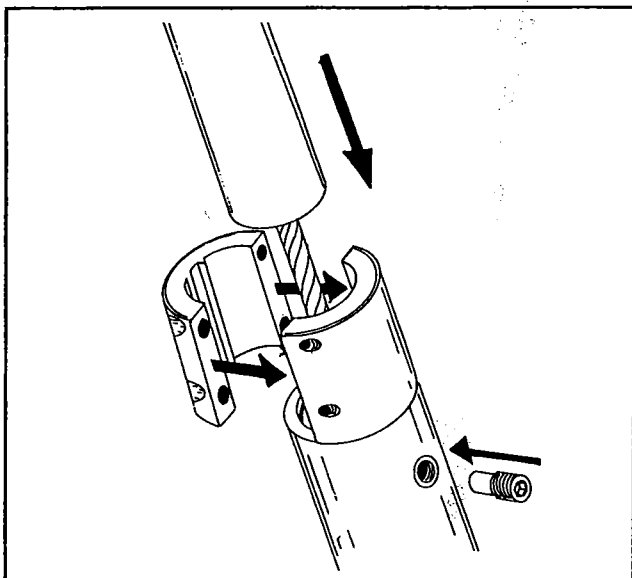

## Step 14

Slide the BOTTOM EXTRUSION down the wire to the TORQUE TUBE.

The BOTTOM EXTRUSION will slide into the TORQUE TUBE until it comes in contact with the STOP PIN.

**NOTE:** The BOTTOM EXTRUSION is 21" long and has four holes in one end. The end with the holes is the upper end.

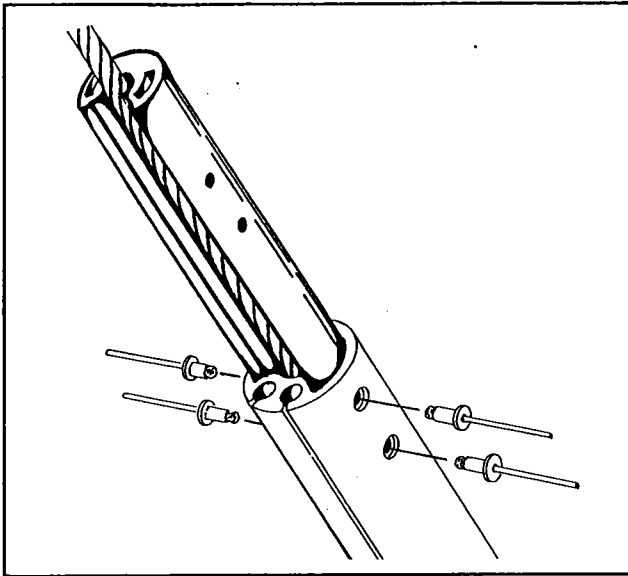

## **Step 15**

Insert the **BOTTOM JOINT / EXTRUSION INSERT** into the top of the **BOTTOM EXTRUSION**.

The **BOTTOM JOINT / EXTRUSION INSERT** has eight holes located near its top end.

The bottom four holes should be aligned with the four holes in the **BOTTOM EXTRUSION**. Fit all four rivets into their holes prior to riveting, then rivet in place.

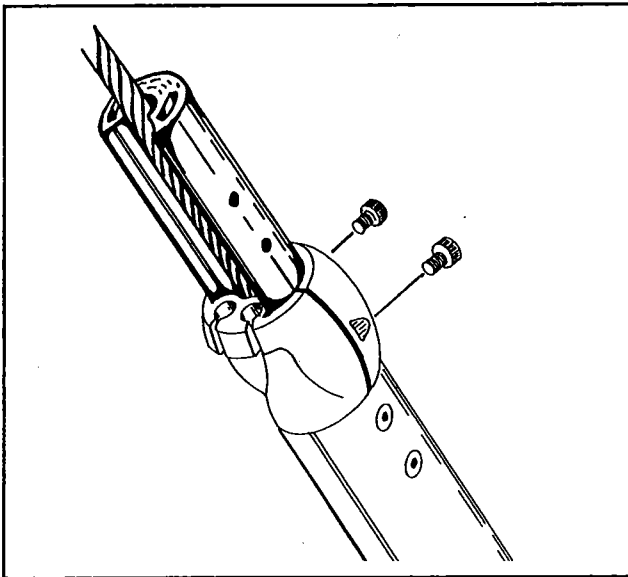

## **Step 16**

Add the stainless steel **SAIL FEEDER**.

The **SAIL FEEDER** should clamp tightly to the **BOTTOM JOINT / EXTRUSION INSERT** and abut the top of the **BOTTOM EXTRUSION**.

Make certain the feeder is installed as shown in the illustration.

Use **LOCTITE® BLUE** on threads.

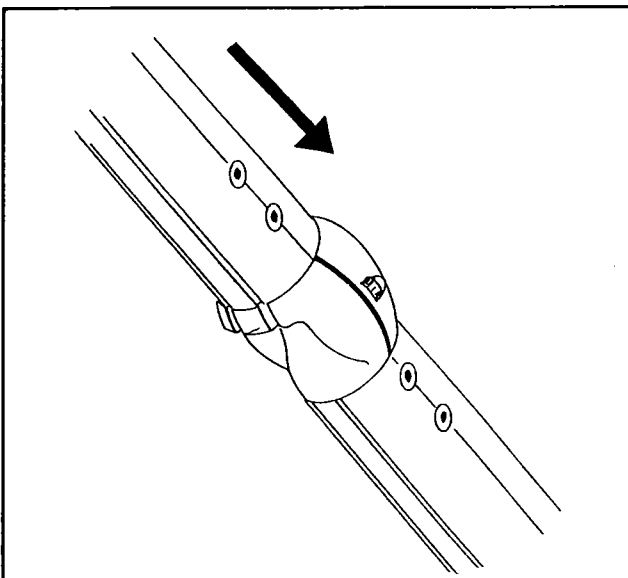

## **Step 17**

Add a **STANDARD SAIL EXTRUSION** over the top of the wire and slide down to butt the top of the **SAIL FEEDER**.

Fit all four rivets into their holes and then rivet in place.

Make certain rivet heads are flush.

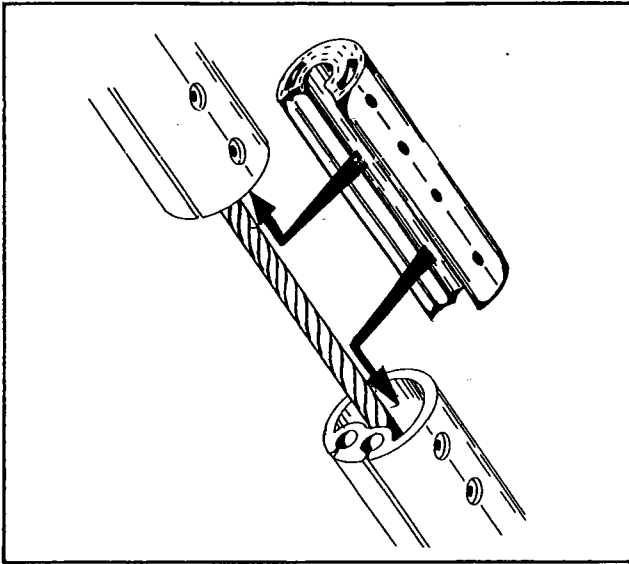

## Step 18

Continue to assemble STANDARD SAIL EXTRUSIONS and JOINT / BEARINGS; riveting each together as you go until you are approximately 8' from the top end of the wire.

Make sure to fit all the rivets in their holes prior to riveting.

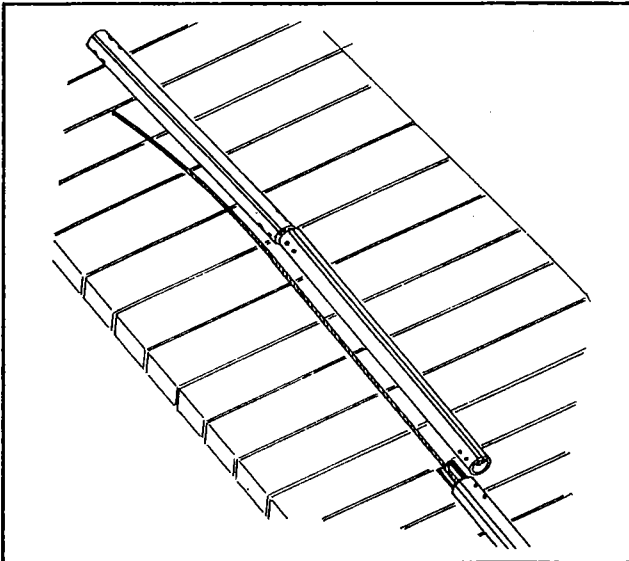

## Step 19

Lay the last two sections of SAIL EXTRUSION alongside the wire in preparation for measurement and cutting. Do not cut or rivet these last extrusions until you read and understand steps 20, 21 and 22.

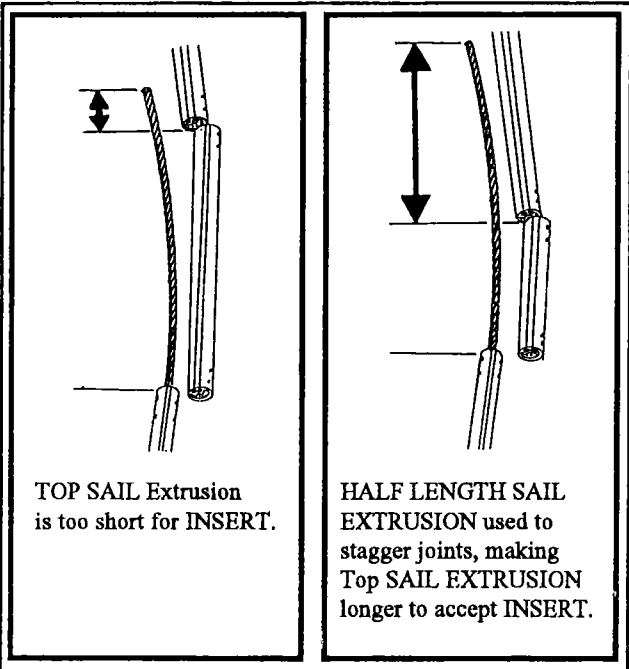

TOP SAIL Extrusion  
is too short for INSERT.

HALF LENGTH SAIL  
EXTRUSION used to  
stagger joints, making  
Top SAIL EXTRUSION  
longer to accept INSERT.

## Step 20

The 24" long UPPER EXTRUSION INSERT will be installed in the top SAIL EXTRUSION in Step 21. It is important that the top SAIL EXTRUSION be at least 30" long when cut in order to accommodate both the INSERT and the standard JOINT / BEARING connection.

If needed, a pre-drilled HALF LENGTH SAIL EXTRUSION has been provided to be used in place of the second from the top full length SAIL EXTRUSION, thus making the top SAIL EXTRUSION long enough to accept the INSERT and JOINT BEARING.

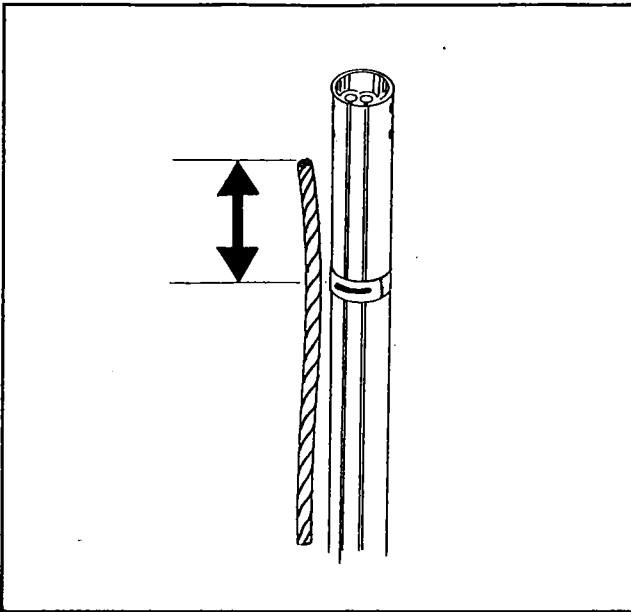

## **Step 21**

Lay the last (uppermost) extrusion alongside the wire and mark 2" from the end of the wire.

Assure that the last section will be no less than 30" as described in STEP 20.

Cut the extrusion with a hacksaw.

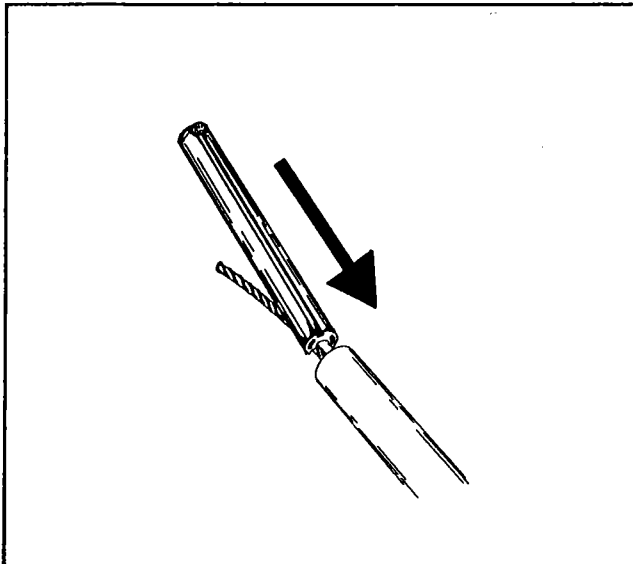

## **Step 22**

Insert the TOP EXTRUSION INSERT into the top of the last sail extrusion.

The TOP EXTRUSION INSERT has a welded "nub" on the upper end to prevent it from sliding down the top SAIL EXTRUSION.

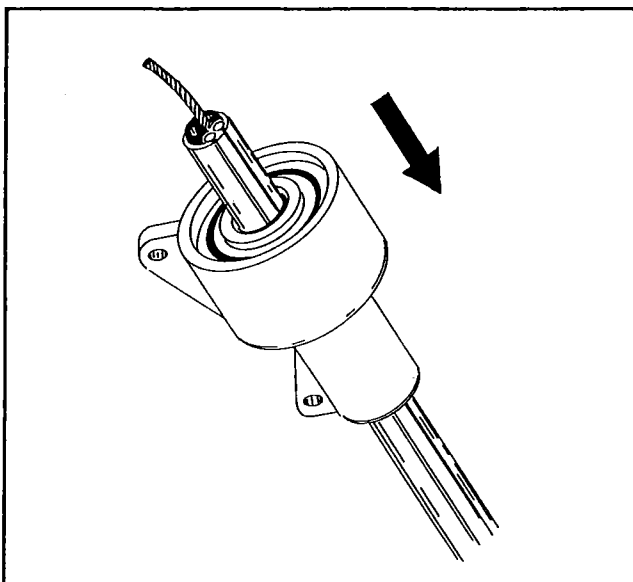

## **Step 23**

Install the UPPER SWIVEL over the top of the system.

**MAKE SURE THE LARGE PORTION OF THE SWIVEL IS UP!**

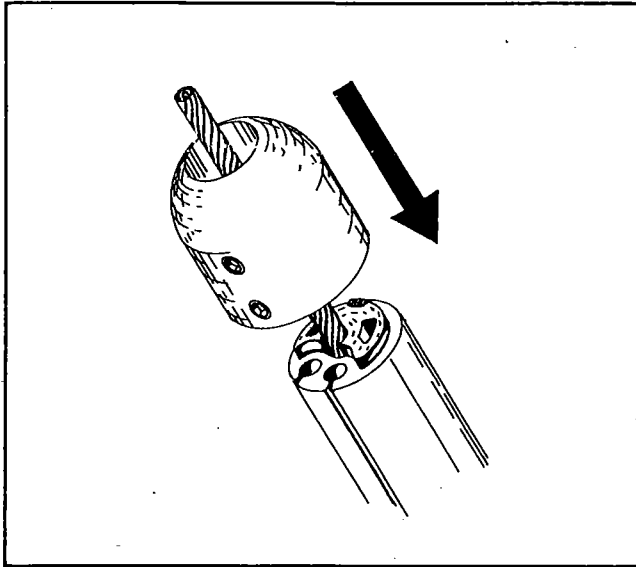

## **Step 24**

Add the TOP CAP to the top extrusion and tighten set screws.

Use LOCTITE® RED on threads of set screws.

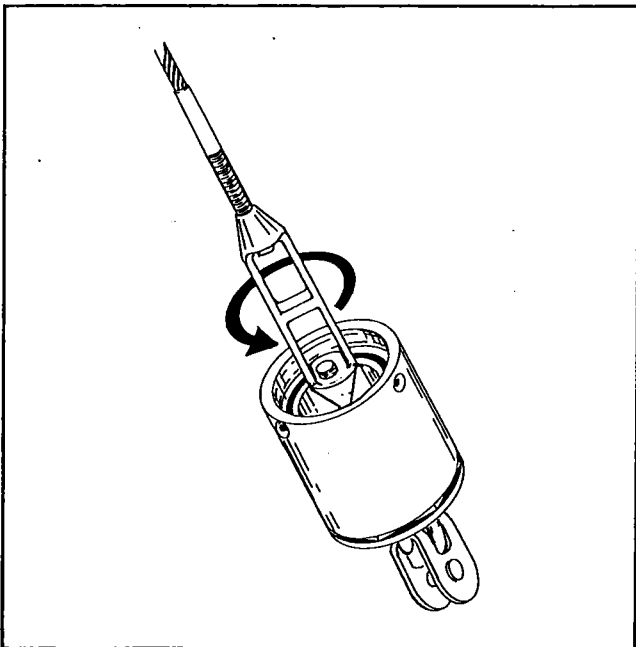

## **Step 25**

Ease the fasteners in the CLAMP and remove the fasteners securing the TORQUE TUBE to the LOWER DRUM UNIT.

Remove the STOP PIN from the TORQUE TUBE.

Slide the TORQUE TUBE up to expose the turnbuckle.

Open the turnbuckle as much as possible and replace the cotter pins (cotter pins should be secure but do not bend them over at this time.)

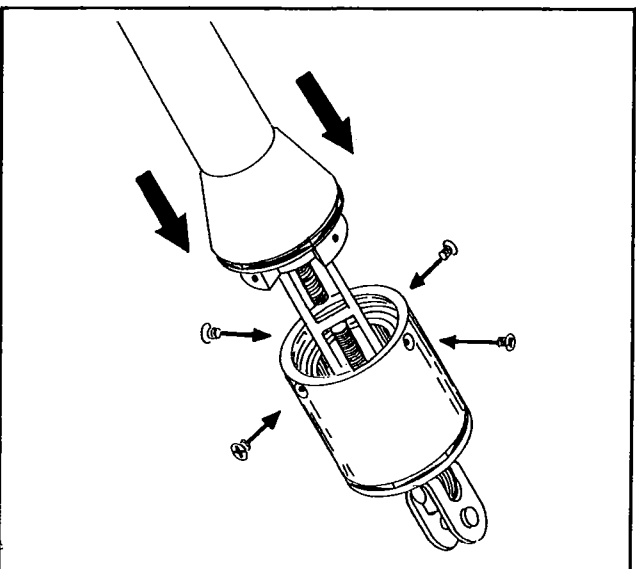

## **Step 26**

Refasten the TORQUE TUBE to the LOWER DRUM UNIT. Adjust the sail extrusions until the STOP PIN can be reinstalled in the TORQUE TUBE. The BOTTOM EXTRUSION should rest on top of the STOP PIN. Tighten the four fasteners on the CLAMP.

**NOTE:** DO NOT APPLY LOCTITE® TO FASTENERS AT THIS POINT. YOU WILL NEED TO REMOVE THE FASTENERS ONE MORE TIME WHEN THE FURLER IS INSTALLED ON THE BOAT.



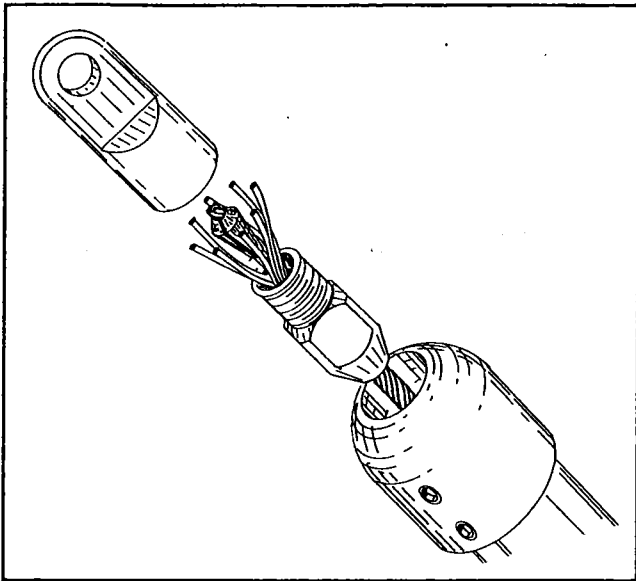

## **Step 27**

Install the STA-LOK® wire fitting following the STA-LOK® instructions.

---

**THE FURLER IS NOW PARTIALLY ASSEMBLED  
AND READY TO BE INSTALLED ON THE BOAT.**

---

### **In preparation for hauling the system aloft :**

1. Slide the UPPER SWIVEL down the extrusions until it rests on top of the FEEDER. Tape or tie in place. If the swivel is not slid down the system at this time, there is a risk that it will slide down in an uncontrolled manner when the system is being raised to the masthead, causing injury to you or your assistants.
2. If the UPPER SWIVEL binds on any of the extrusion joints, the rivet heads should be checked to assure they are flush. Drill out bad rivets with an 1/8" drill and replace.

### **Hauling the system aloft :**

1. Tie a halyard to the top of the system with a series of half hitches. Do not try to lift the system from or with the Bosun's chair. Use the second halyard to adjust the system into position to replace the rigging pins at the masthead.
2. Once the masthead pin is in place, swing the drum unit into position and pin at the stemhead.

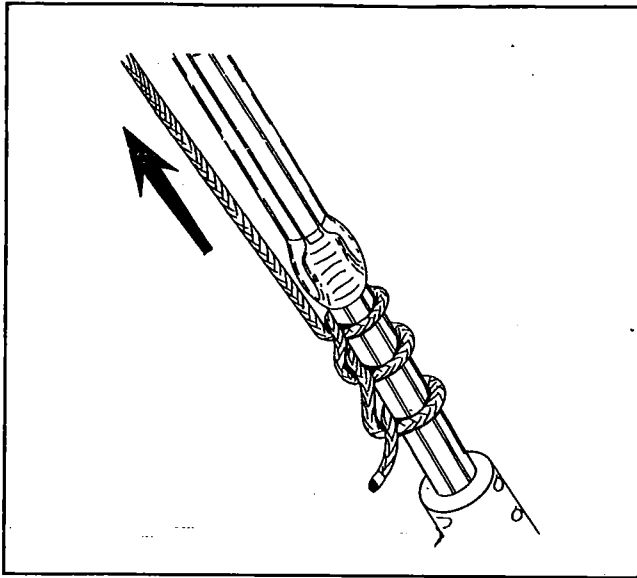

### **Step 28**

Support the SAIL EXTRUSIONS with the jib halyard by tying a series of half hitches below the SAIL FEEDER, then take up the slack on the halyard.

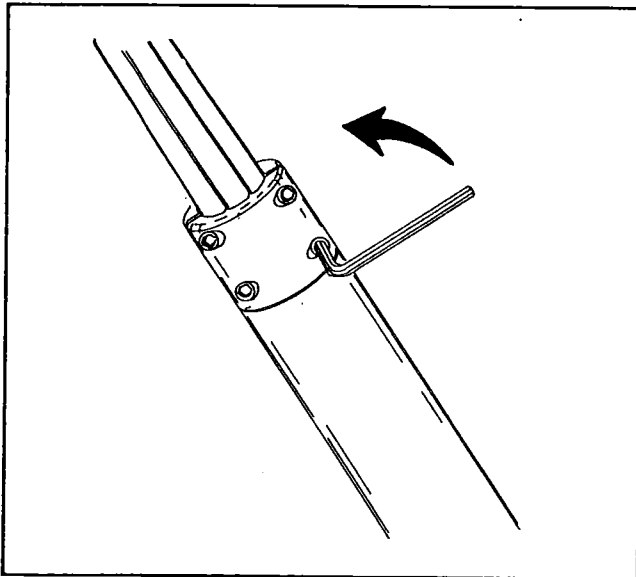

### **Step 29**

Loosen the four fasteners in the CLAMP. DO NOT REMOVE THE FASTENERS.

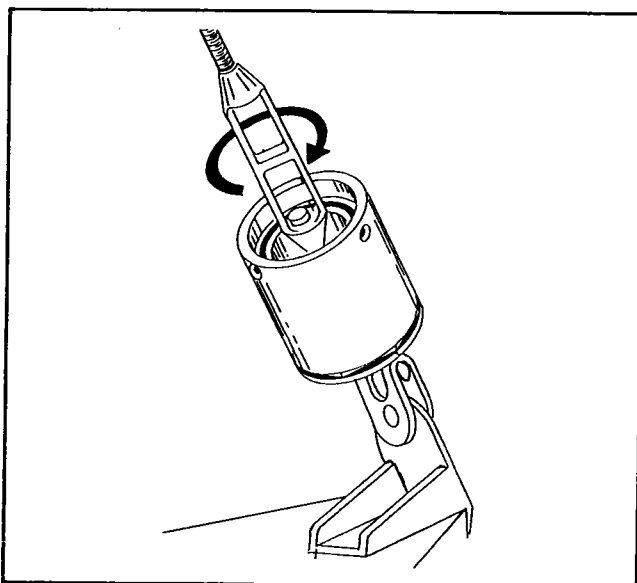

### **Step 30**

Remove the four fasteners holding the TORQUE TUBE to the LOWER DRUM.

Remove the STOP PIN from the front of the TORQUE TUBE.

Slide the TORQUE TUBE up to reveal the turnbuckle .

Adjust the turnbuckle as required to tighten the headstay and tune the rig.

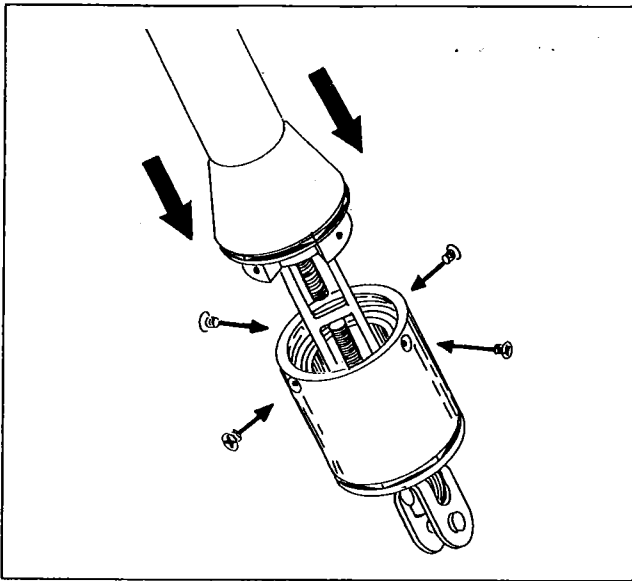

### Step 31

Lower the TORQUE TUBE back down onto the LOWER DRUM and replace the fasteners.

Use LOCTITE®-BLUE on the threads of the fasteners.

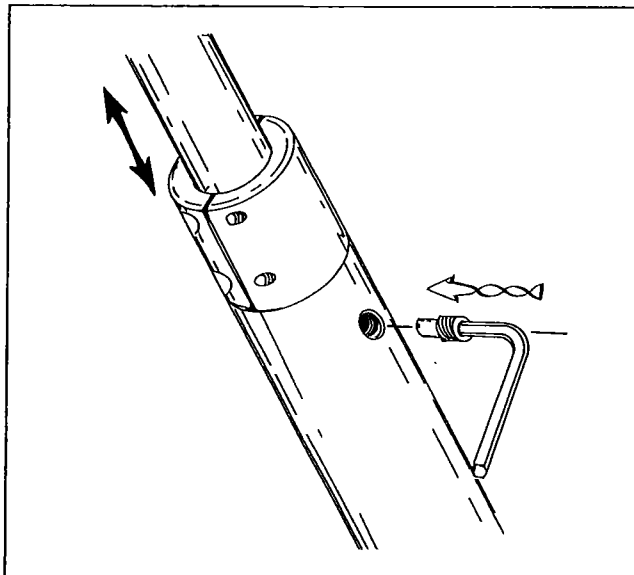

### Step 32

Adjust the SAIL EXTRUSIONS up or down so that the STOP PIN can be replaced in the TORQUE TUBE.

Insert the STOP PIN in until it is flush with the outside of the EXTRUSION. *Do not overtighten.*

The SAIL EXTRUSIONS should rest on top of the STOP PIN. This pin will prevent the SAIL EXTRUSIONS from dropping down and damaging the turnbuckle.

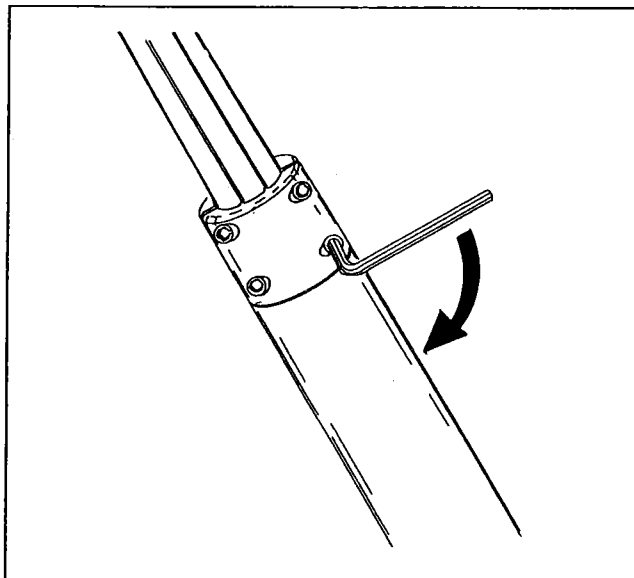

### Step 33

Tighten the CLAMP fasteners.

Make sure the grooves in the CLAMP align with the grooves in the SAIL EXTRUSIONS.

Use LOCTITE® BLUE on the fastener threads.

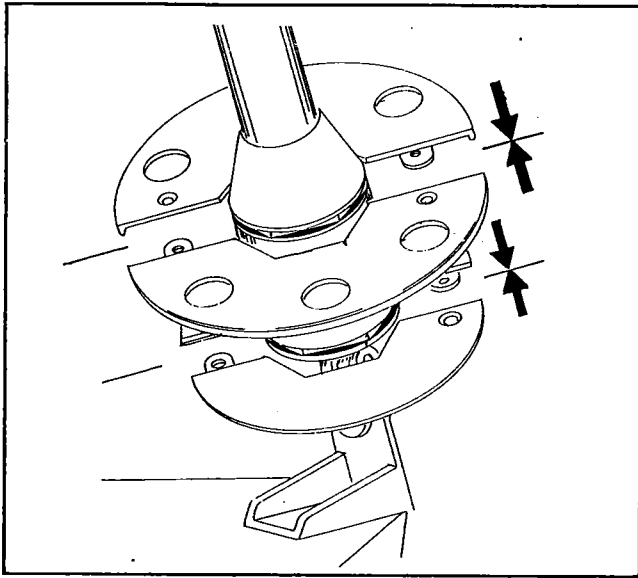

### **Step 34**

Replace bottom and top SPLIT PLATES on the LOWER DRUM / TORQUE TUBE ASSEMBLY.

Use LOCTITE® - BLUE on fastener threads.

We suggest that you tie or tape a line onto these plates to prevent them from accidentally being dropped in the water.

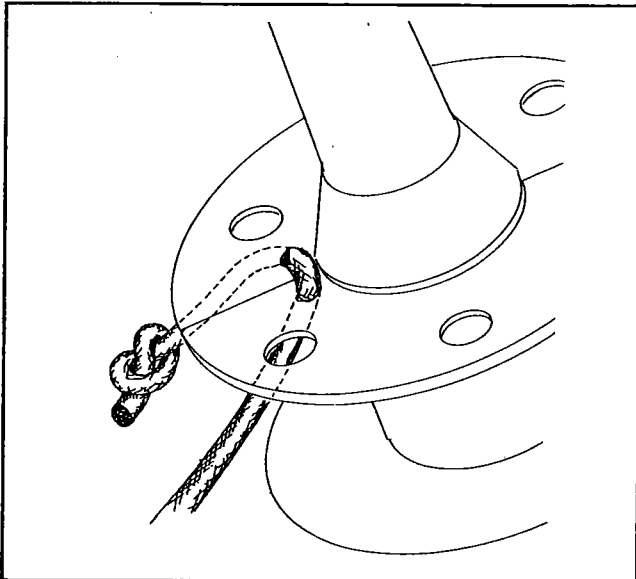

### **Step 35**

Add the control line to the TOP PLATE.

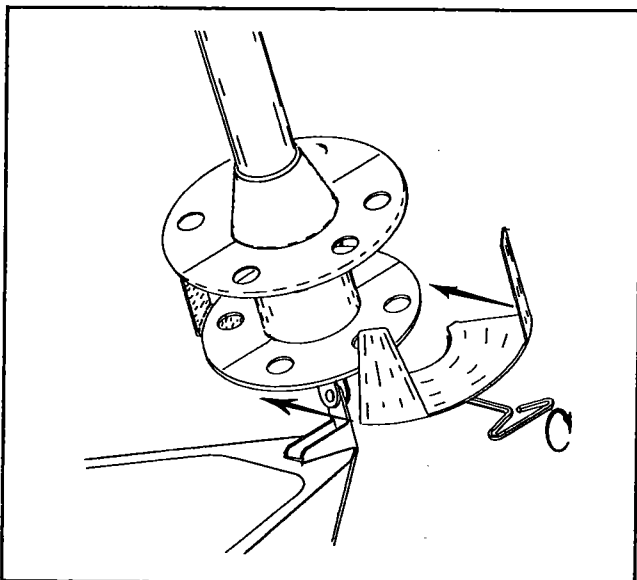

### **Step 36**

Install the STAINLESS STEEL CAGE with the special long handled allen wrench provided in the kit.

Rotate the cage as required to assure a fair lead for the control line.

Use LOCTITE® - BLUE on the fasteners.

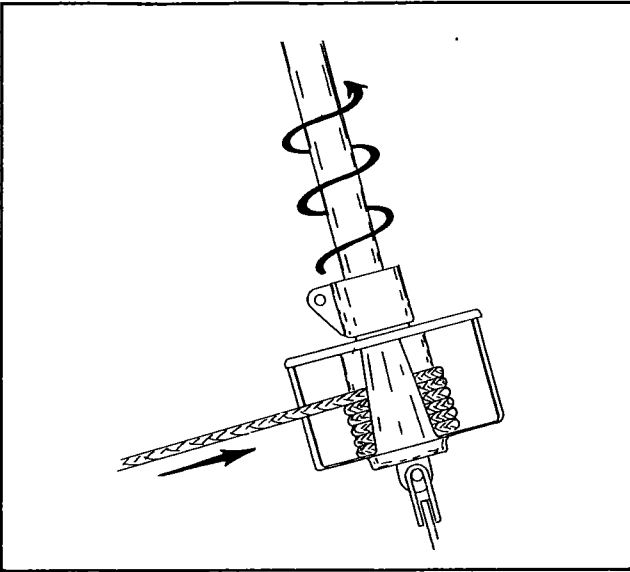

### **Step 37**

If your Sails have been supplied with a sun cover sewed on the port side of the leach of the sail, rotate the entire furling system in a counter clockwise direction to wind the control line onto the drum.

If your sails have the sun covers sewed on the starboard side, rotate the system in a clockwise direction.

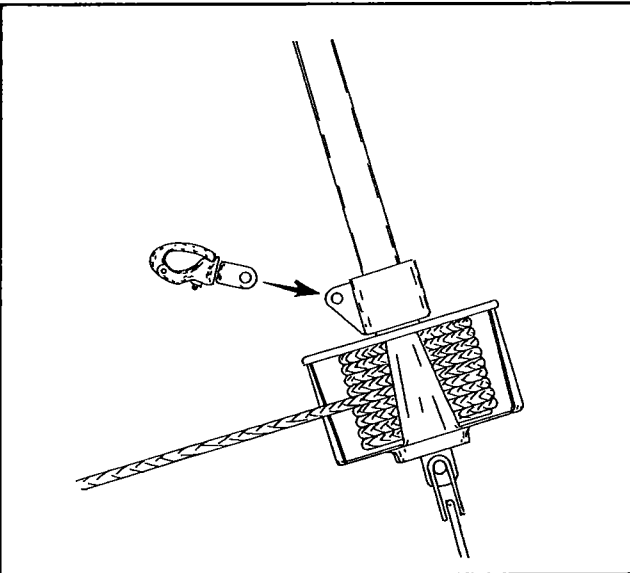

### **Step 38**

Attach the TACK SNAP SHACKLE to the ear on the bottom of the TORQUE TUBE.

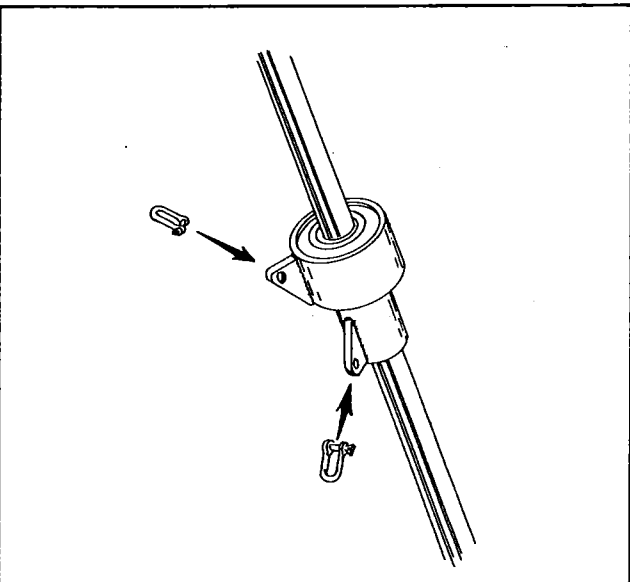

### **Step 39**

Attach the two " D " SHACKLES to the ears on the UPPER SWIVEL.

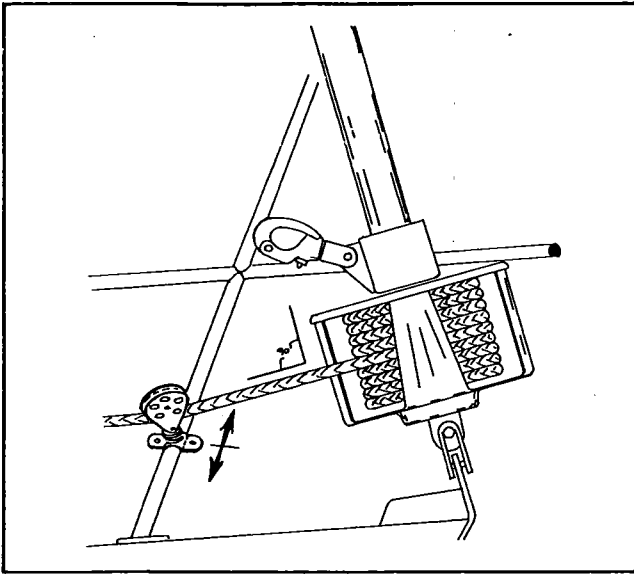

### **Step 40**

Check that the control line lead into the LOWER DRUM UNIT lines up with the middle of the DRUM.

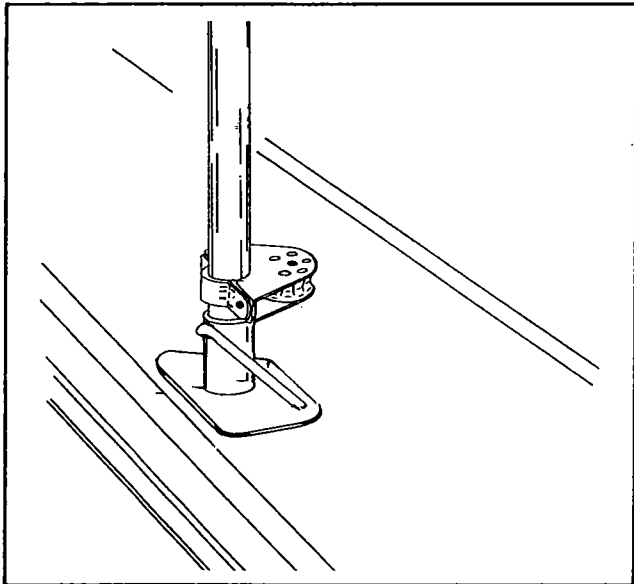

### **Step 41**

Install lead blocks on the stanchions to guide the control line back to the cockpit.

***CONGRATULATIONS !***

**THE FURLING SYSTEM IS NOW COMPLETE AND READY FOR YOUR JIB.**

## **CAUTIONARY NOTES ON HALYARD ANGLES AND SWIVEL HEIGHT.**

It is extremely important to inspect the final installation of the furler with the sail to assure that the angle of pull on the UPPER SWIVEL by the halyard is parallel to, or slightly aft of the angle of the headstay. It may be necessary to utilize a "PULL-BACK" device mounted on the mast to obtain the proper angle.

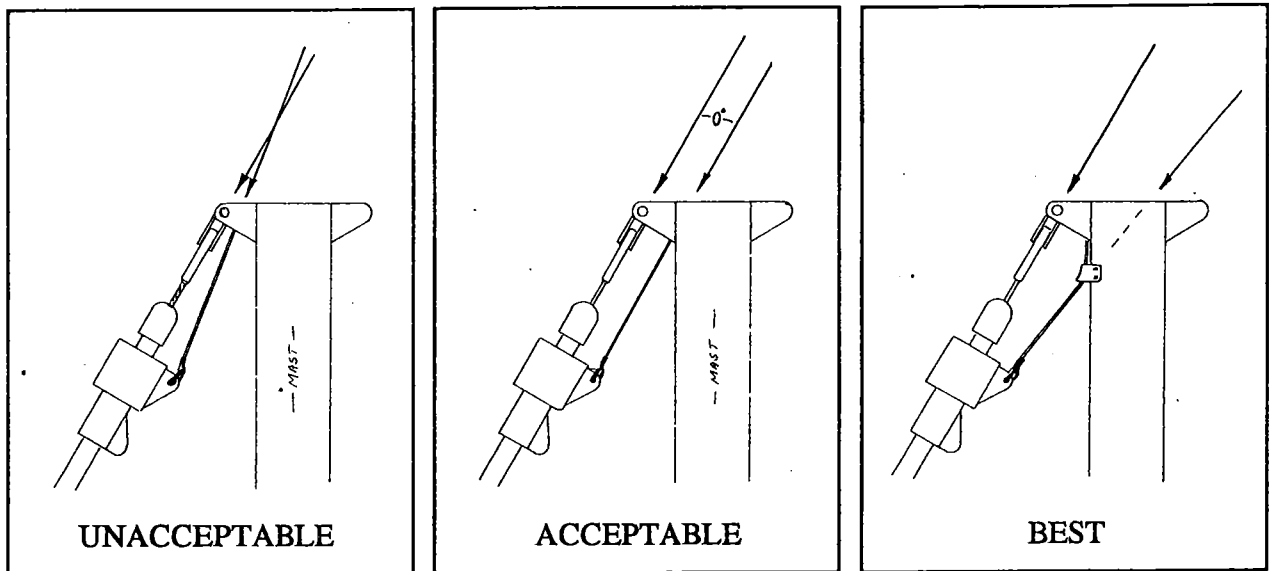

In addition, make sure that the UPPER SWIVEL is no more than 6" down from the TOP CAP. Use tack pennants or head pennants to relocate the UPPER SWIVEL if it is too low.

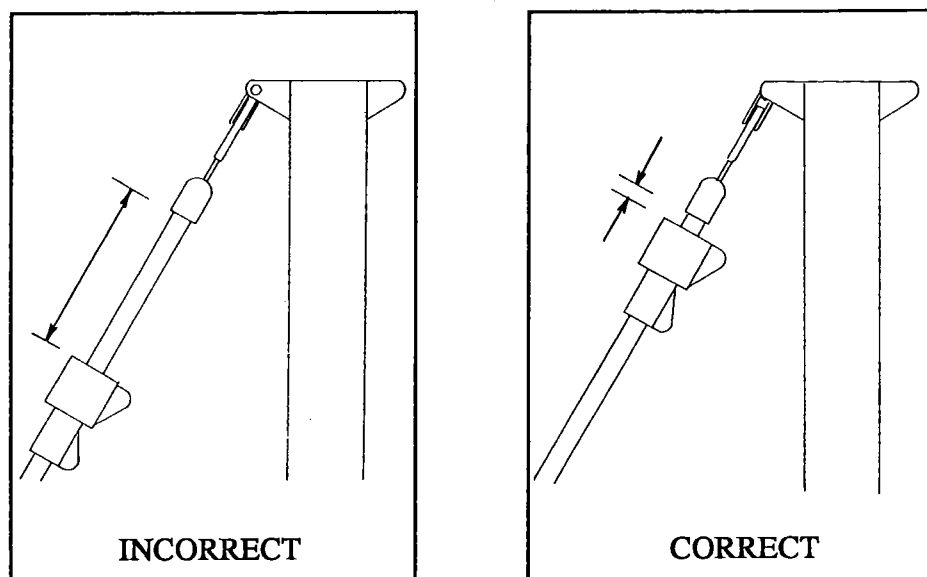

### **AVOID HALYARD WRAP !**

Failure to correct either of these installation related problems will increase the likelihood of the halyard becoming entangled or "wrapped" around the furler extrusions. This condition could damage the furler, halyard or headstay and could result in the loss of the mast. Please be diligent with your installation.

## **INSTALLATION OVER EXISTING ROD HEADSTAYS:**

The installation procedures for rod headstays are essentially the same as for wire headstays. The step-by-step procedures listed in these instructions apply to rod headstays .

The primary difference is that the rod headstay cannot be cut on the dock and reheaded without special equipment. Coil the headstay and take it to a rigger who has a heading machine for rod.

You will shorten the rod 5 1/2" at the top and utilize a new two-piece eye fitting instead of the Sta-Lok® fitting described in these instructions. The two piece eye fitting is composed of a lower portion, or NOSE and an upper portion, or EYE. The NOSE will be fitted onto the rod prior to heading . The NOSE and reheaded rod then will pass through the SAIL EXTRUSIONS.

When the furling system is fully assembled over the rod, the EYE will be threaded onto the NOSE to complete the headstay.

The SYSTEM 2000 SAIL EXTRUSIONS will accept any NOSE with 1/2" diameter threads.

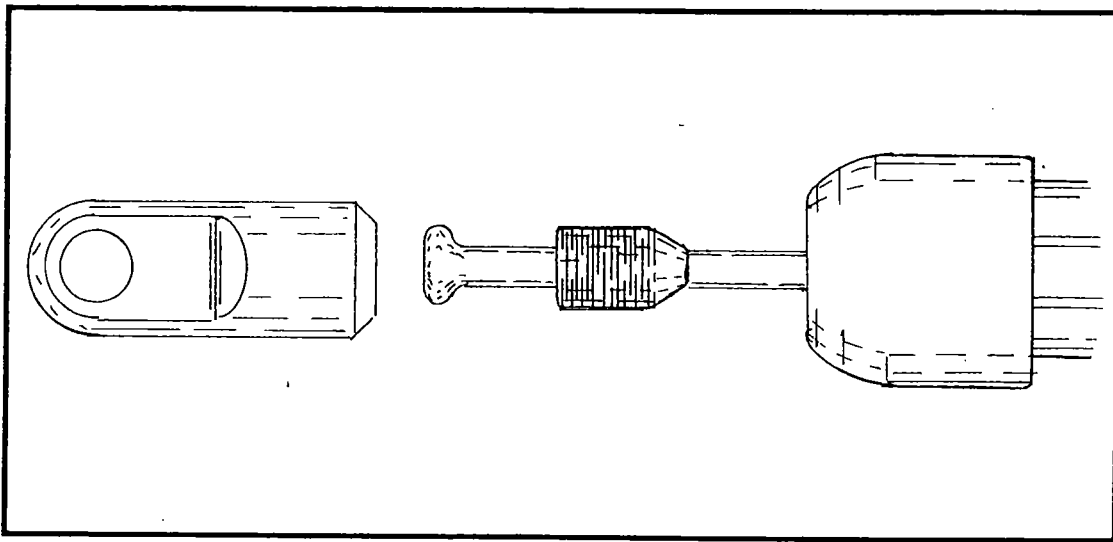

## **Maintenance:**

The SYSTEM 2000 should require only minimal attention to provide you with many years of use.

We suggest that you flush the bearings occasionally with fresh water and that you inspect the control lines for chafe.

It is also advisable to drop the jib occasionally and lubricate the sail tape with a teflon spray or parafin to prevent the tape from corroding into the sail groove.



## **CONVERSION FOR RACING:**

The Schaefer 2000 Furling system can be easily converted for use as a headstay foil . This will allow you to use "full hoist " racing sails and also allow you to change headsails without going "bare headed ". Simply remove the SAIL FEEDER and lower the UPPER SWIVEL down to rest on top of the TORQUE TUBE. Replace the SAIL FEEDER . Next, remove the STAINLESS STEEL CAGE, TOP PLATE and BOTTOM PLATE. Full hoist sails can now be tacked on deck and hauled aloft in either of the sail grooves by the halyard.

## **WHEN YOU LEAVE YOUR BOAT:**

The jib must be tightly and completely furled on the furling system and the control line cleated securely before you leave your boat.

It is often the case when returning to the harbor at the end of a day of sailing that there is little or no wind, perhaps you are even under power. If you furl the sail in these conditions you will notice that the jib rolls up very loose and uneven. If you leave the jib in this condition there is a risk that when the sail is exposed to a brisk breeze it will tighten itself around the furler and a portion of the clew will begin to flog. This could cause damage to the jib and the boat.

Prevent this from happening by keeping a light pressure on the jib sheets when furling the sail and by rolling the systems a few extra turns so that the jib sheets are wrapped around the sail several times.

In addition to securing the control line it is also advisable to tie off the DRUM with a short length of line as a safety. The addition of a safety line will prevent damage that could occur if someone working on your boat inadvertently released the control line prior to leaving the boat.

## **SEVERE STORM CONDITIONS:**

We advise you to remove the jib when you leave the boat unattended for any length of time or prior to severe storms. This will reduce windage, helping to reduce pressure on the mooring or anchoring equipment.