

Stoppers can be adjusted in 10° intervals

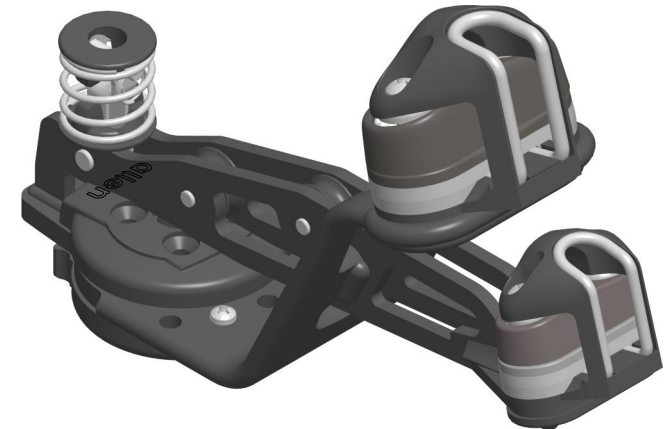
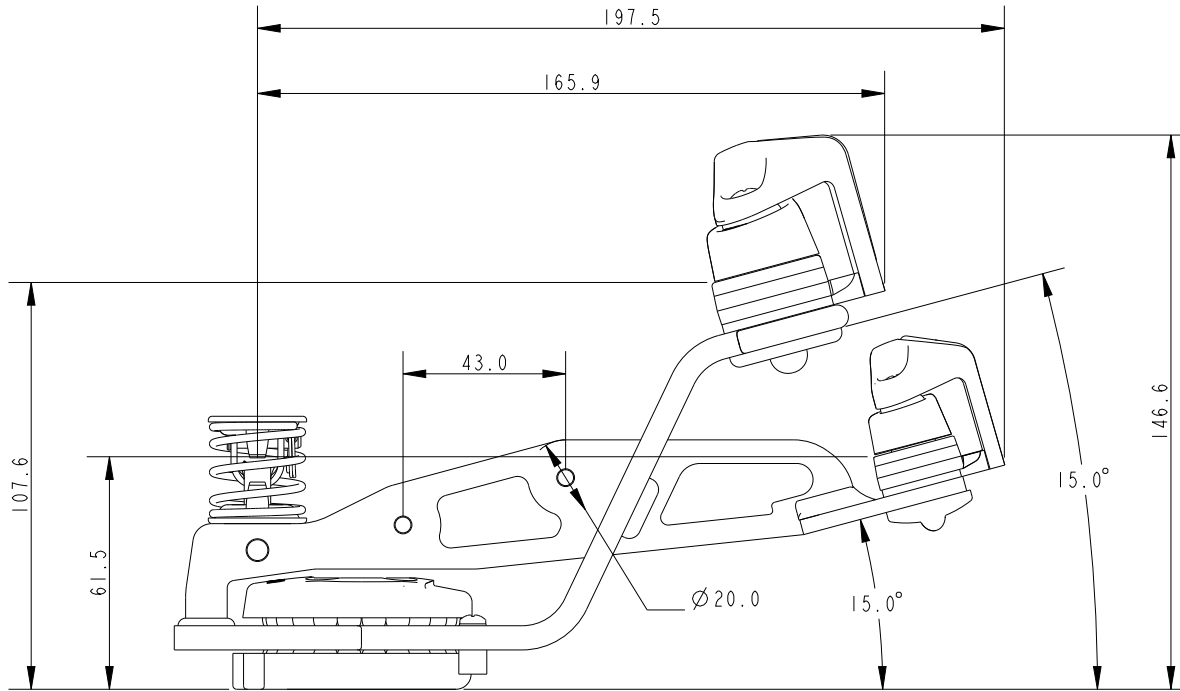

Specification				
HWD mm	Fixing Hole Size	Fixing Hole Pitch mm	MWL kg	Weight g
147x73x220	M5	19.5 x 19.5	600	513

DIMENSIONS FOR REFERENCE ONLY
 allenbrothers.co.uk
 +44(0)1621 772477

Title	Description
A5166DUAL-REF	Dual Arm Centre Jammer