

SCALE 1:2

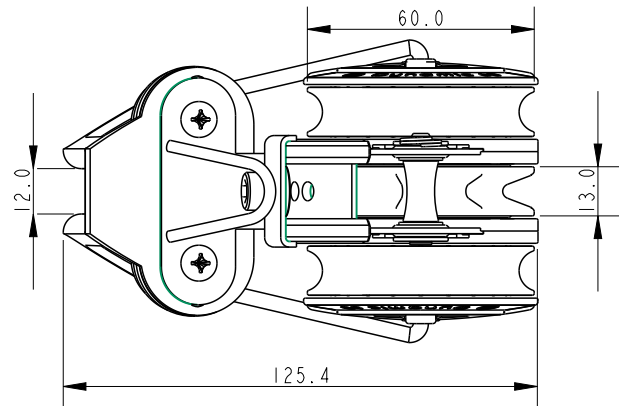

SCALE 1:2

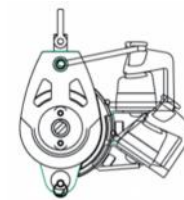

34.5° of Adjustment, with 4 Positions at 11.5° Intervals

DIMENSIONS FOR REFERENCE ONLY
allenbrothers.co.uk
+44(0)1621 772477

Specification

Length mm	Line Diameter mm	Shackle Pin mm	Breaking Load kg	MWL kg	Weight g	Bearing Detail
143	10	5	1250	600	535	Stainless Steel

Title	Description
A2068-REF	Triple With Ratchet And Adjustable Cleat